

# Operational Amplifier(OPAMP)

Operational amplifier is a direct-coupled amplifier used to perform wide variety of linear and some nonlinear operations which is usable in the frequency range from 0 to few MHz.

(TOAL No of Slides is 14)

# Some features of OPAMP

- OPAMP was designed to perform mathematical operations such as summation, subtraction, multiplication, differentiation, integration etc. in analog computer.
- OPAMP can also be used for the purpose of solution of simultaneous linear algebraic equation as well as differential equation.
- Now a days OPAMPs are available almost all in IC forms having comparatively low price.
- Many useful circuits can be designed using OPAMP and so this has become very popular in electronic industry.

# Pin Diagram & Circuit symbol of OPAMP

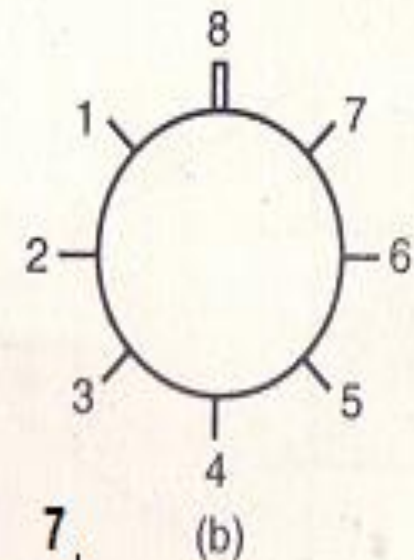
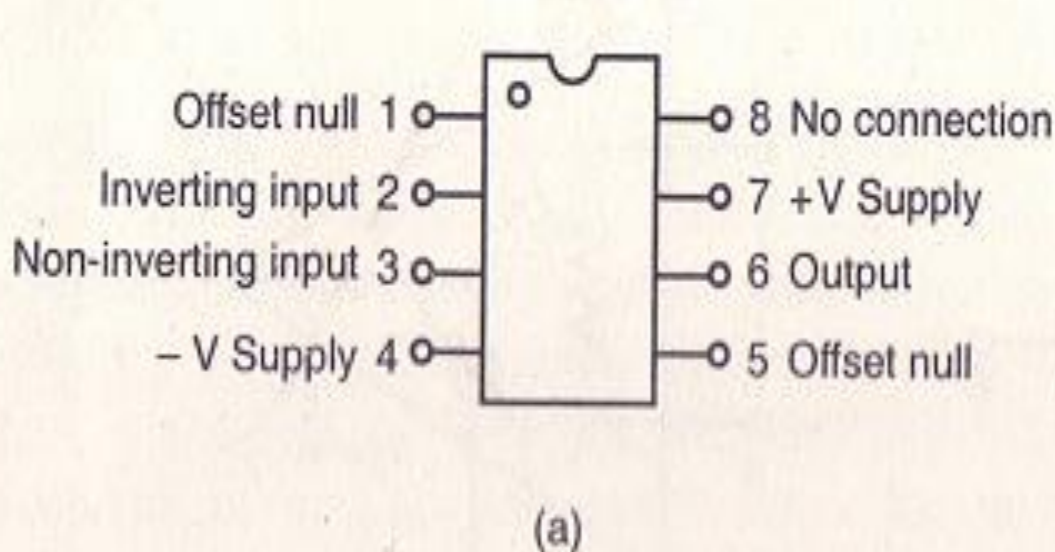

Fig. 1: Pin diagram of an OP AMP  
(a) in DIP package  
(b) metal case package

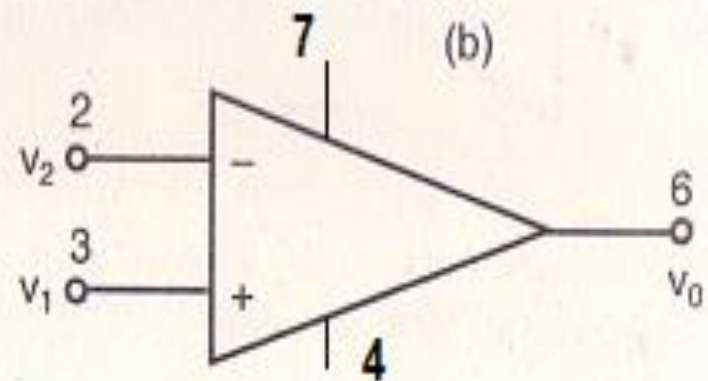

Fig. 2: Circuit symbol of OP AMP

# Characteristics of ideal OPAMP

- Open loop voltage gain is infinite
- Input impedance is infinite
- Output impedance is zero
- Bandwidth is infinite
- Perfect balance i.e, output is zero when two input voltages are equal.
- Characteristics do not drift with temperature
- **Common mode rejection ratio** is infinite
- **Slew rate** is infinite

# Deviations of practical amplifier from ideal one

In practical OPAMP

- Open Loop Voltage gain is not infinite
- Input impedance is not infinite
- CMRR is not infinite
- Output is not zero even if two input voltages are identical. The voltage which should be applied between the input terminals to balance the amplifier is called **input offset voltage**. where as the **input offset current** is the difference between the two bias currents entering into the input terminals of balanced amplifier and **input bias current** is the average of two separate currents entering the input terminals of a balanced amplifier.

# Applications of OPAMP

OPAMP can be used both in inverting mode and non inverting mode. However OPAMP can be used for designing

- i) Scale changer
- ii) Phase Shifter
- iii) Unity gain follower
- iv) Adder
- v) Subtractor
- vi) Differential amplifier
- vii) Integrator
- viii) Differentiator

# Inverting Amplifier

- Op-amp are almost always used with a negative feedback:
  - Part of the output signal is returned to the input with negative sign
  - Feedback reduces the gain of op-amp
  - Since op-amp has large gain even small input produces large output, thus for the limited output voltage (lest than  $V_{CC}$ ) the input voltage  $v_x$  must be very small.
  - Practically we set  $v_x$  to zero when analyzing the op-amp circuits.

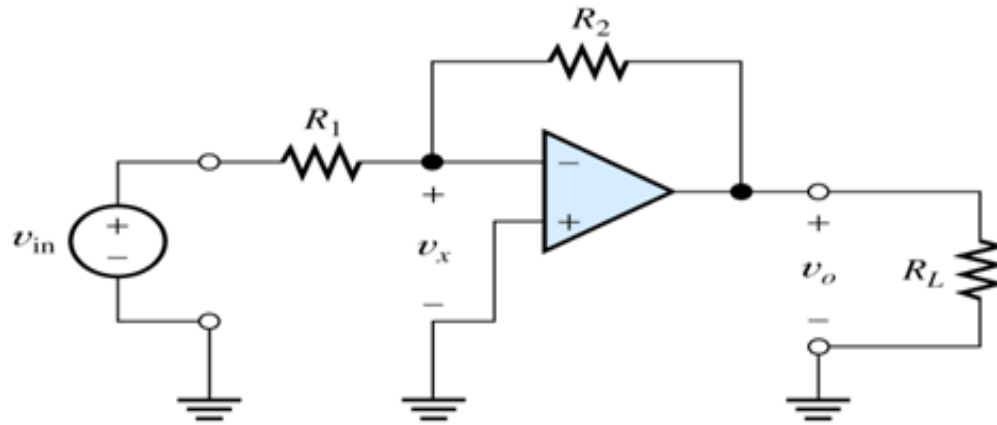

Fig.3: The inverting amplifier.

$$\text{with } v_x = 0 \quad i_1 = v_{in} / R_1$$

$$i_2 = i_1 \quad \text{and}$$

$$v_o = -i_2 R_2 = -v_{in} R_2 / R_1$$

SO

$$A_V = v_o / v_{in} = -R_2 / R_1 \quad \dots\dots\dots(1)$$

# Scale changer and Phase Shifter

- From (1) , 
$$v_0 = -\frac{R_2}{R_1} v_s = -k v_s$$

i.e the circuit multiplies the input by  $-k$  and so such circuit can be treated as scale changer.

If,  $R_1$  and  $R_2$  is replaced by impedances  $z_1$  and  $z_2$  and they are chosen in such a way that they have equal magnitude but different phase then

$$\frac{v_0}{v_s} = -\frac{I z_2 I e^{j\varphi_2}}{I z_2 I e^{j\varphi_1}} = e^{j(\pi + \varphi_2 - \varphi_1)}$$

Where  $\varphi_1$  and  $\varphi_2$  are respectively the phase angles of  $z_1$  and  $z_2$ . Thus the OPAMP can shift the phase of input voltage by the angle  $\pi + \varphi_2 - \varphi_1$



# Non Inverting Amplifier

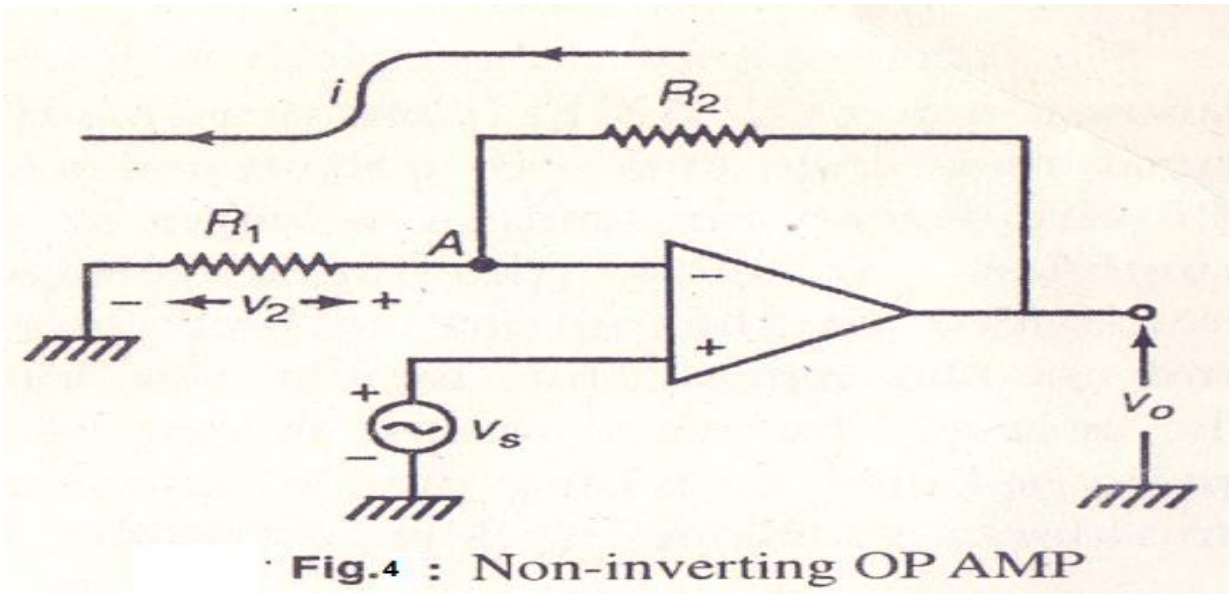

Here signal is applied in non-inverting terminal. Since gain  $A \rightarrow \infty$

There is a virtual short at the input terminals and so,

$$\frac{v_o - v_2}{R_2} = \frac{v_2 - 0}{R_1}$$
$$\text{or, } \frac{v_o}{v_s} = \frac{v_o}{v_2} = 1 + \frac{R_2}{R_1} \quad \dots\dots\dots(1)$$

# Unity gain follower

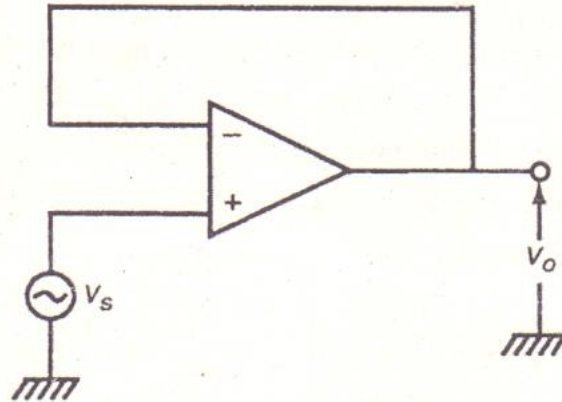

From eq (2) it is found that the closed loop gain becomes unity if we choose  $R_1 = \infty$  and/or  $R_2 = 0$ . The amplifier then acts as a voltage follower i.e., a non-inverting amplifier with unity gain.

# OPAMP as Adder

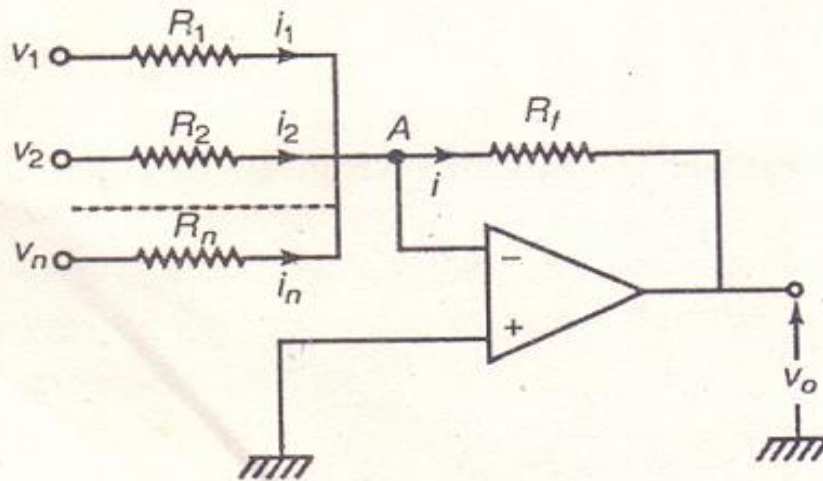

Adder using OP AMP

If  $R_1 = R_2 = \dots = R_n$  then

$$v_o = -\frac{R_f}{R_1}(v_1 + v_2 + \dots + v_n)$$

Since the point A may be treated as virtual ground we can write

$$i_1 + i_2 + \dots + i_n = i$$

$$\text{or } \frac{v_1}{R_1} + \frac{v_2}{R_2} + \dots + \frac{v_n}{R_n} = -\frac{v_o}{R_f}$$

$$\therefore v_o = -\left(\frac{R_f}{R_1}v_1 + \frac{R_f}{R_2}v_2 + \dots + \frac{R_f}{R_n}v_n\right)$$

Thus the output is proportional to the algebraic sum of the inputs.

# OPAMP used for difference of two signals

In this circuit

$$\frac{v_2 - v_a}{R_1} = \frac{v_a - v_0}{R_2} \dots\dots(i)$$

$$\frac{v_1 - v_b}{R_1} = \frac{v_b - 0}{R_2} \dots\dots(ii)$$

Putting  $v_a = v_b$  and subtracting Eq. (i) from (ii)

we get, 
$$v_0 = \frac{R_2}{R_1}(v_1 - v_2)$$

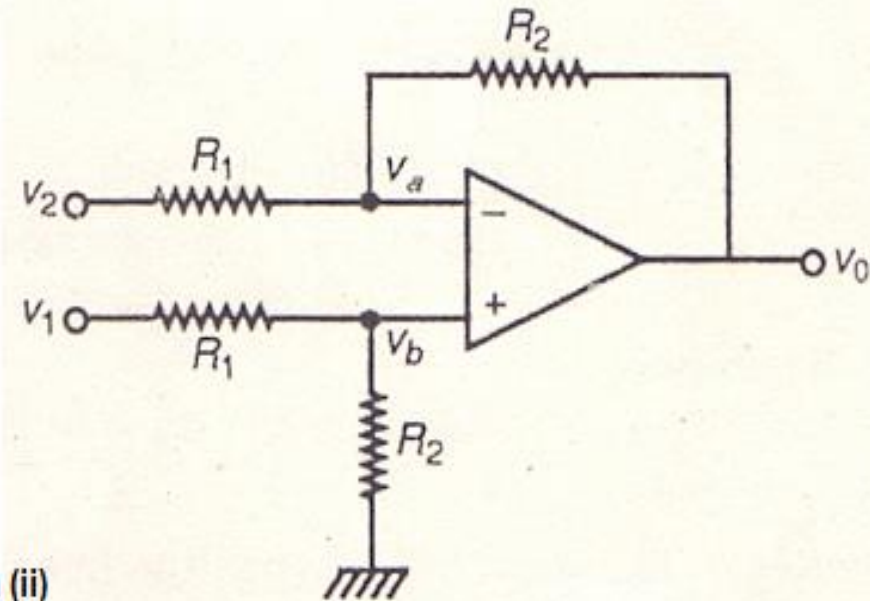

Differential amplifier

Thus the circuit amplifies the difference of two input signals.

# OPAMP as Integrator

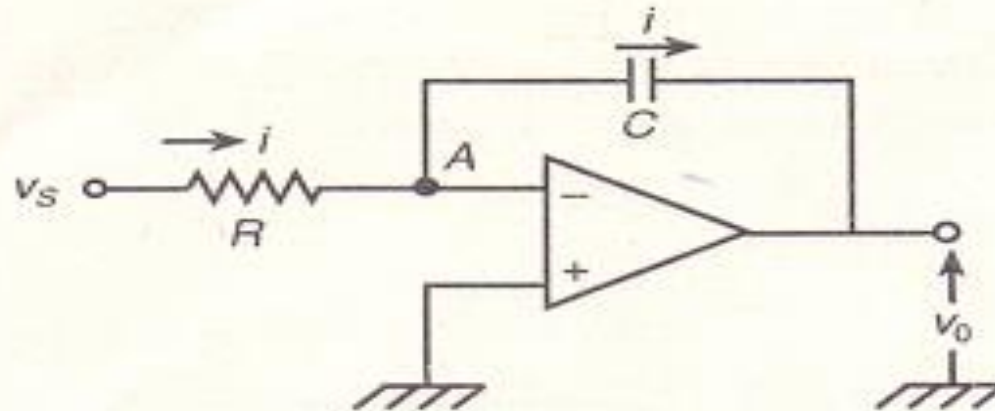

**In this circuit**

$$i = \frac{v_s - 0}{R} = \frac{dq}{dt} = -\frac{d}{dt}(Cv_o)$$

where we take  $q = C(0 - v_o)$  as the instantaneous charge on the capacitor.

Hence the output voltage  $v_o = -\frac{1}{CR} \int v_s dt + K$

where the integration constant  $K$  depends on the initial condition i.e., the initial capacitor voltage.

# OPAMP as differentiator

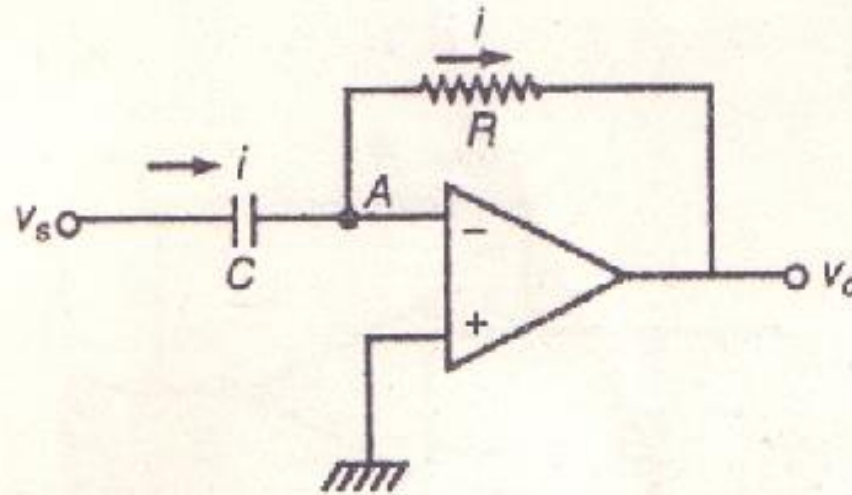

In this circuit

$$i = \frac{dq}{dt} = \frac{d}{dt}(Cv_s) = \frac{0 - v_o}{R}$$

where we take  $q = Cv_s$  as the instantaneous charge on the capacitor.

$$\text{Therefore, } v_o = -CR \frac{dv_s}{dt}$$